

**terraza**   
**PROFILES**

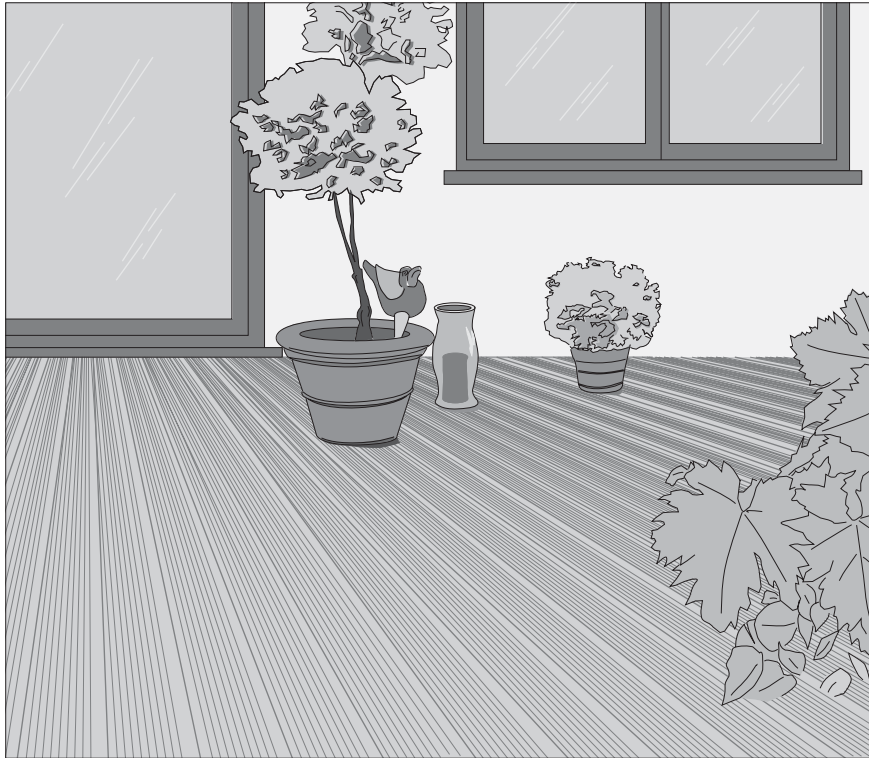

**INSTALLATION INSTRUCTIONS**

Version 10/2007

***werzalit***<sup>®</sup>  
**LASTING. BEAUTY.**

Profiles

terraza profile

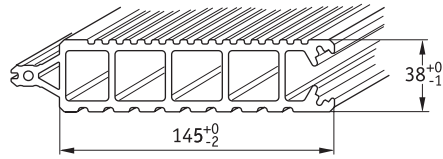

Starting profile

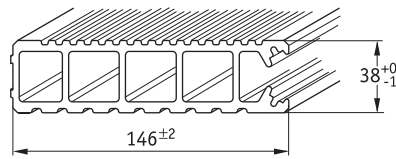

End profile

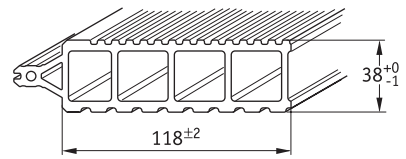

Sub-framework

Sub-framework bar

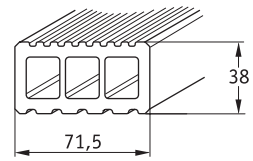

Edge termination

End cap

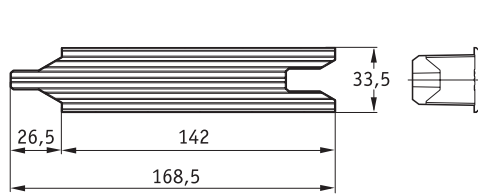

End strip

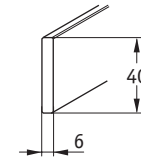

Accessories

Bracket for sub-framework bar

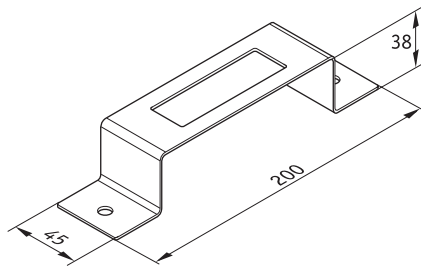

Rubber pads

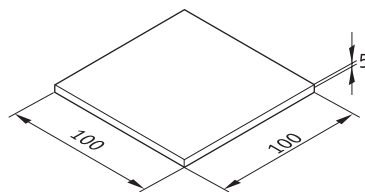

Other fastening parts

Universal screw H 6 x 45

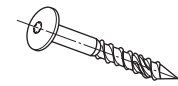

Spacer sleeve K7



Screws (stainless steel A2)

Pan head screw 4.0 x 20



Recessed head screw 4.0 x 50

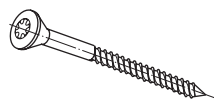

End cap



Laying variations

Laying with approx. 3 mm joint = coverage width 148 (+0/-2) mm

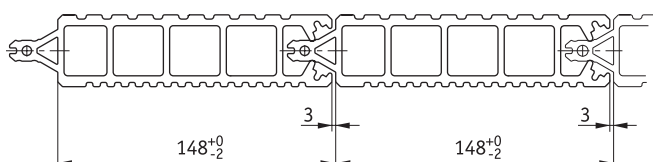

Laying with approx. 10 mm joint = coverage width 155 (+0/-2) mm

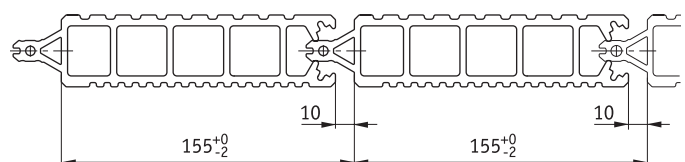

## Applicability/questions?

The information in these installation instructions is based on standard laying situations. Due to the endless diversity of possible floor layouts and terrace sizes, not every single application can be addressed with these installation instructions.

We would be happy to prepare detailed laying recommendations for specific floor layouts, buildings or deviating design structures. Please contact our Product Management + Building Service department, email: [objektservice@werzalit.de](mailto:objektservice@werzalit.de)

These installation instructions may be changed at any time without prior notice as a result of technical advancements. The most recent version is always available on the internet ([www.werzalit.co.uk](http://www.werzalit.co.uk)). Please follow the instructions since no warranty can be provided in the event of deviation from these installation instructions.

## Areas of application

Self-supporting flooring on garden terraces, roof terraces, garden paths, concrete balconies, carport floors, etc.

For applications that require approval by building authorities, a load-bearing, closed substructure with sufficiently calculated dimensions is required as a base for the terraZa profiles or the sub-framework bars.

## Expansion

Fluctuations in temperature and moisture levels cause the terraZa profiles to expand and contract in their length, width and thickness dimensions. This is illustrated by the arrows in the diagram.

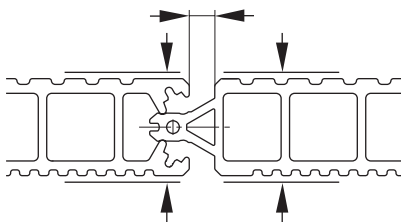

**The expansion of the profiles may be up to max. 6 mm/m of profile length or width of the surface (coverage width).** This must be factored in when laying the profiles by using expansion joints at all fixed borders (e.g. building walls, garden walls, shafts, door frames, posts, railings, rain pipes, etc.); otherwise, stresses may arise that result in warping or bulging of the flooring.

☛ See page 4, *Expansion joints*

## Laying as floating floor

To ensure expansion of the surface is free of resistance, the sub-framework must in principle be laid as a floating floor (no fixed fastening to the foundation).

**Exception: Only the sub-framework edge bars must be fastened to the foundation.**

☛ See page 5, *Laying the sub-framework*

## Ventilation

The entire terrace structure must have good back ventilation. For unhindered air circulation, the open space beneath the surface and between the sub-framework elements may not be filled.

☛ See page 4, *Ventilation*

## Surface drainage

Falling precipitation must in principle be drawn away from the building with a surface gradient of at least 1% (1 cm/m) in the lengthwise direction of the laid terraZa profiles.

☛ See page 5, *Laying of the sub-framework*

**For applications in which no terrace surface gradient is possible, we recommend using our terraZa tiles.**

☛ See *Installation Instructions terraZa Tiles*

## Cutting

The terraZa profiles can be sawed, milled or drilled with all typical woodworking tools.

## Laying variations

The terraZa profiles can be laid in many variations:

2 different surfaces (fine/coarse), 2 different joint widths (approx. 3 mm/approx. 10 mm) and 4 different colours can be mixed together in any combination. In addition, various laying directions are also possible, such as diagonal.

## Changes in colour

The terraZa profiles are dye penetrated and fade naturally over the course of time without losing the basic character of their colour.

As these are wood-based products, colour variations over time, caused by UV rays and moisture, are natural and to be expected. During the first weeks and months in particular (depending on weather conditions), a change in colour may occur, but this does not indicate a defect.

Slight colour fluctuations within a profile or a batch are natural and highlight the natural character of wood. However, these even out after development of the patina (natural greying of wood).

## Cleaning/care

The terraZa profiles require no special care. However, larger instances of soiling should be cleaned off shortly after they occur.

To do this, brush off the terraZa profiles lengthwise with warm water and typical household cleansers using a normal household cleaning tool. For stubborn dirt, a high-pressure cleaner may be used (no rotary nozzle).

Spots and stains of oil, grease, mustard, etc. can be removed well with the following products:

- anti-stain spray
- grease remover
- multi-purpose cleaner

Using a brush can also be very helpful. Afterward, rinse off the profile well with a large quantity of water.

## Disposal

Scraps (cutting waste) can be disposed of as household or commercial waste. Larger quantities should be disposed of as bulky refuse or at a recycling centre.

## 1. Expansion joints

Expansion joints must be situated at all solid borders (e.g. house walls, shafts, garden walls, door frames, posts, rain pipes, etc.). **The size of the expansion joints should be at least 20 mm on all sides.**

☛ See Figure 1

**Terrace surfaces with a total width (coverage width of the profiles) or total length (profile length) greater than 6 m must be divided into sub-areas by consistent separating joints.** ☛ See Figure 2

The size of the separating joint (**b**) must be at least 8 – 10 mm. For calculation of the required border joint size (**a**), the total expansion of max. 6 mm/m depending on the length or width of the sub-area minus the size of the separating joint (**b**) must be taken into account.

The calculation takes place using the formula:

$$a = ((A \text{ m} + B \text{ m}) \times 6 \text{ mm/m} - b \text{ mm}) / 2$$

**Example:**  $a = ((6 \text{ m} + 6 \text{ m}) \times 6 \text{ mm/m} - 10 \text{ mm}) / 2$

$a = 31 \text{ mm}$  joint size on each side

As an alternative to consistent division into sub-areas over the entire width (coverage width of the profiles), a regular arrangement of 10 mm joints (large grid pattern) every max. 10 profiles (approx. 1.50 m) in each section can be created.

**Terrace surfaces larger than 60 m<sup>2</sup> (or larger than 10 m coverage width) must generally be laid with the 10 mm joint (large grid pattern).**

### Expansion joints for mitre laying

When laying with mitre joints, an expansion joint of at least 5 mm must be created at the mitre joint. The maximum profile length to be laid up to the next consistent separating joint is 6 m. ☛ See Figure 3

The mitre joint must be created on a sub-framework bar that is fastened to the foundation.

☛ See page 5, *Fastening of the sub-framework edge bars*

## 2. Ventilation

The entire terrace structure must have good back ventilation. In order to ensure unhindered air circulation, the open space beneath the surface and between the sub-framework elements may not be filled.

For terrace surfaces situated at ground level, a border of supporting plate or the like should be provided as separation from the turf or soil. A direct connection between the terrace surfaces and turf or soil should absolutely be avoided.

For proper ventilation, an open ventilation gap of at least 20 mm is required around the entire surface. ☛ See Figure 4

## 3. Foundation properties/preparation of the foundation

A load-bearing, consolidated foundation of ballast, gravel, water-bound macadam, chippings, concrete or the equivalent is required. Sufficient drainage must be provided to prevent pooling; if necessary, a drain should be installed. ☛ See also Figure 4

### Natural ground (soil)

In the case of unconsolidated ground, the soil should be dug out accordingly. Then stones or water-bound macadam should be poured in, covered with an approx. 5 cm thick layer of gravel bed and spread to at least a 1% gradient in the lengthwise direction of the **terraza** profiles to be laid. Finally, concrete paving slabs of approx. 40 x 40 x 5 cm should be laid as a base for the sub-framework bars (see laying spacing).

### Concrete floors (poured concrete slab)

For a level and firm floor covering with a sufficient gradient, the sub-framework bars are laid on the bare concrete slab (see Laying spacing), with rubber pads 100 x 100 x 5 mm placed underneath them to allow water arising on their undersides to flow away unhindered.

### Roof terraces and concrete balconies with top-side sealing layer (bitumen sheeting, etc.)

Concrete paving slabs of approx. 40 x 40 x 5 cm should be laid (see laying spacing) for load distribution over an area and as a base for the sub-framework bars. To protect the sealing layer against mechanical damage, rubber pads 100 x 100 x 5 mm or sections of protective matting should be placed underneath the slabs. It is not necessary to lay out protective matting over the entire surface.

Figure 1

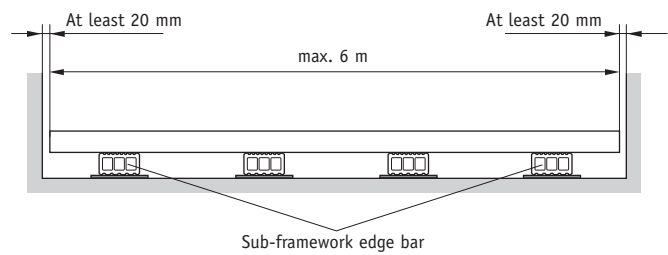

Figure 2

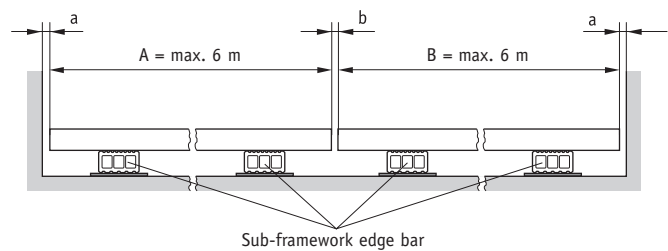

Figure 3

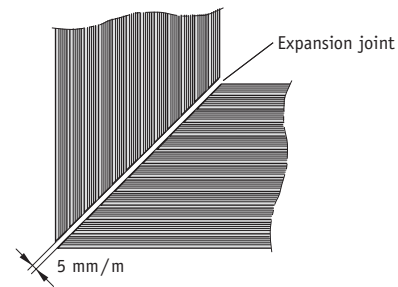
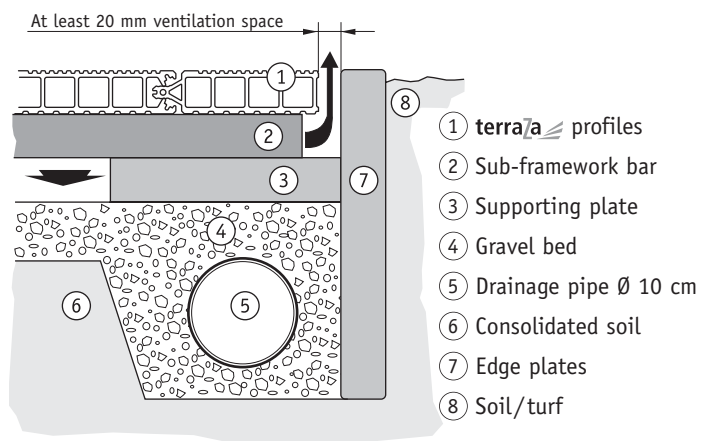

Figure 4



## 4. Laying spacing

The laying spacing  $X$  of the sub-framework bars corresponds to the fastening spacing of the **terraza** profiles and is:

- max. 600 mm (centre-to-centre)

For diagonal laying of the **terraza** profiles, the laying spacing  $X$  of the sub-framework bars should be reduced according to the laying angle.

### Example:

- For a laying angle  $60^\circ$ ,  $X = 520$  mm
- For a laying angle  $45^\circ$ ,  $X = 420$  mm

The support spacing  $Y$  for the sub-framework bars (clear distance between support points) is:

- max. 400 mm for sub-framework bars laid flat
- max. 500 mm for sub-framework bars laid vertically

☛ See Figure 5

For high loads, e.g. carport floors, the laying spacing  $X$  and the support spacing  $Y$  for the sub-framework bars must be halved.

## 5. Laying of the sub-framework

The sub-framework bars must have point-like support. Direct laying in soil, on the gravel bed or on the concrete floor is not permitted. Attention must be paid to the required gradient of at least 1% in the lengthwise direction of the **terraza** profiles to be laid later.

☛ See Figure 6

Bar joints must have at least a 20 mm air gap and must be arranged with offset surfaces.

### Important!

Due to varying climatic influences (e.g. large short-term temperature fluctuations, varying influences from moisture and heat on partially covered or shaded areas, non-functioning air circulation beneath the surface, etc.), it is possible that the **terraza** profiles could tend to bow up (curve) at the face end.

For this reason, it is necessary to fasten the sub-framework edge bar to the foundation, however without restricting expansion. The manner of fastening depends on the existing structure design. The sub-framework edge bars are understood as the outermost sub-framework bars of each surface (even sub-areas) on both face sides of the **terraza** profiles.

☛ **Sub-framework edge bars, see also Figures 1 and 2**

### Fastening of the sub-framework edge bars

#### a) For concrete slab supports

The sub-framework edge bars are fastened to the concrete slabs at every support point with dowels and stainless steel flathead screws. The sub-framework bar must be drilled through in the centre and the screw head countersunk.

☛ See Figure 7

**Alternative: For grown soil,** typical ground anchors can be placed between each of the support slabs and the sub-framework bars connected to these with cable binders or the like.

☛ See Figure 8

#### b) For concrete floors

The sub-framework edge bars are fastened at every support point with a bracket that must be raised up appropriately based on the height of the sub-framework. The bracket must be positioned so that the sub-framework edge bar can shift outward without restrictions after installation of the **terraza** profiles.

☛ See Figure 9

Figure 5

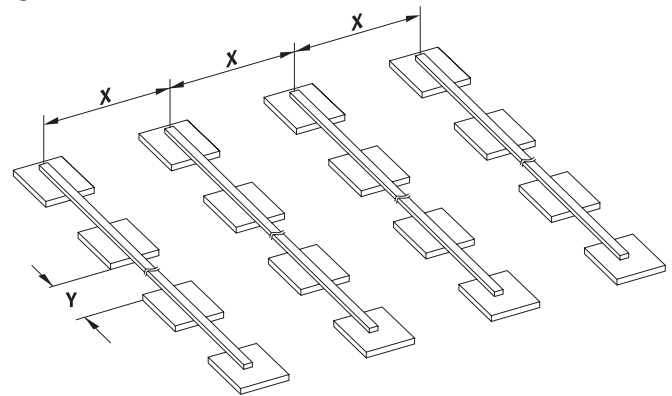

Figure 6

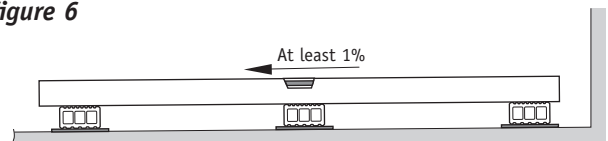

Figure 7

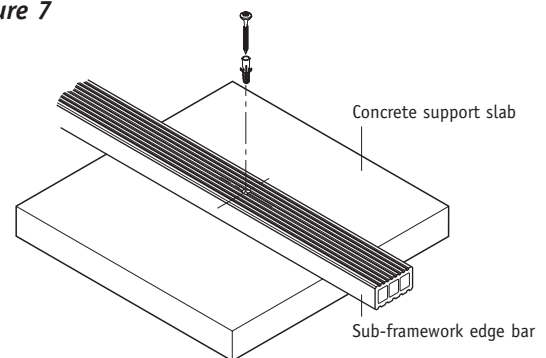

Figure 8

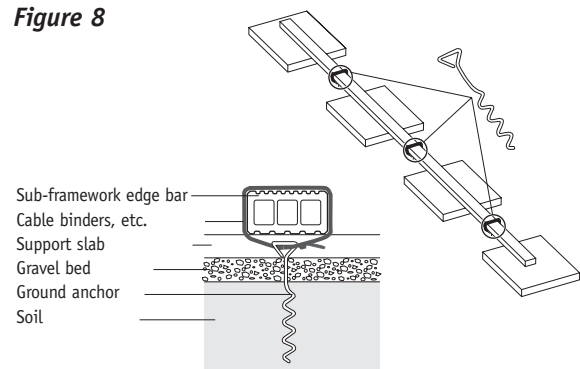
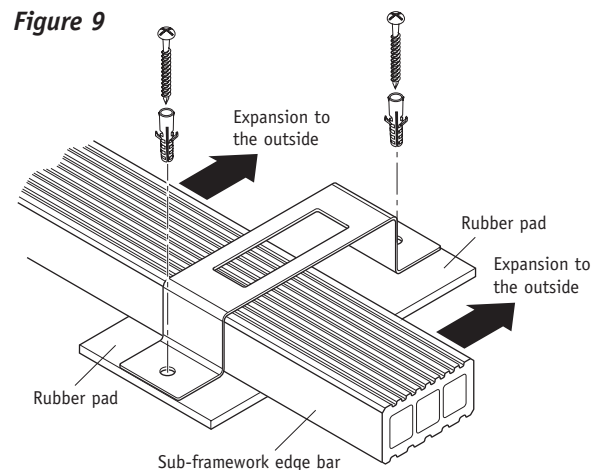

Figure 9



## 6. Laying of the profiles /cutting

The **terraza** profiles can be sawed, milled or drilled with all typical woodworking tools.

In principle, the **terraza** profiles must be screwed into every sub-framework bar. It is important here that the profile always rests flush against the sub-framework bar. For short profile lengths < 1.20 m, a 3-point support is generally required.

For screwing into helical grooves, do not screw in the screws too deeply with force since this risks splitting the helical groove. Overturning of the screws also reduces the fastening strength and can result in damage over time.

### Start of laying

Hidden screwing of the starting profile without drilling into the profile helical groove using **terraza** pan head screws 4.0 x 20 mm, also visible screwing very close to a profile frame in sunken hole Ø 4 mm with **terraza** recessed head screw 4.0 x 50 mm, paying careful attention to straight alignment of the profile. The starting profile can be individually adapted in width, if necessary.

➤ See Figure 10

### Continuation of laying

Click the **terraza** profiles in place to the desired joint width, regularly tapping the profile into place with a rubber hammer and using a strip of wood as bolster between the profile and hammer. When tapping in the profile, **always start at the profile end** (like a zipper).

➤ See Figure 11

**Important: Before screwing, lift the profile slightly so that it sits correctly in the pattern and has not been pounded in too deep.**

### End of laying

Visible screwing of the end profile very close to a profile frame in sunken hole Ø 4 mm with **terraza** recessed head screw 4.0 x 50 mm. The end profile can also be individually adjusted in width.

➤ See Figure 12

### Profile excess length

The side allowable profile overhang is max. 100 mm

➤ See Figure 13

### Profile longitudinal joints

Profile longitudinal joints can be created without joining (butt joint) up to a max. total profile length of 6 m. These longitudinal joints must be staggered (offset by at least 1 span). The profile joint must take place on a flat (horizontal) sub-framework bar and both profile ends must be screwed to this. For vertically laid sub-framework bars, 2 sub-framework bars must be laid next to each other at the profile joint and screwed together.

➤ See Figures 14 and 15

### Profile disassembly

If it is necessary to disassemble profiles, we absolutely recommend using a wood bolster and tapping diagonally against the profile edge.

➤ See Figure 16

Figure 10

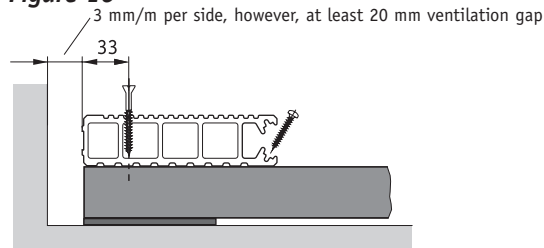

Figure 11

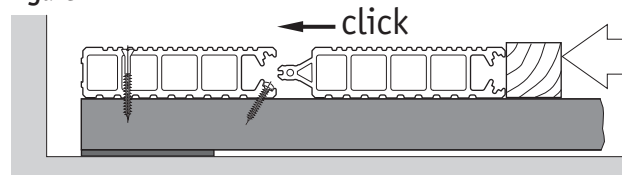

Figure 12

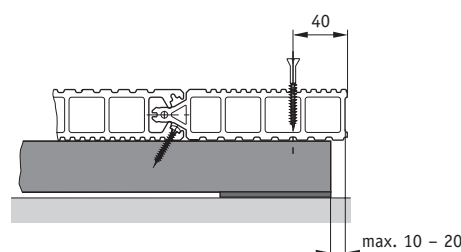

Figure 13

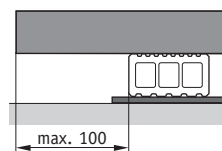

Figure 14

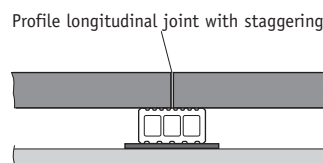

Figure 15

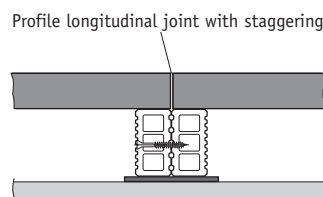
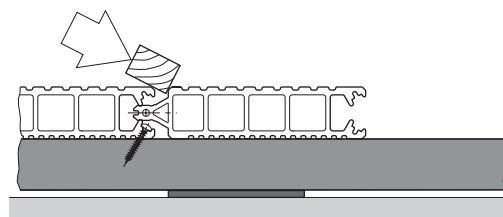

Figure 16



## 7. Edge covering

Right-angled cut edges can be sealed if necessary with **terraza** end caps.

☛ *siehe Bild 17*

For angled cut edges, a **terraza** starting profile can be used as edge frame (frieze). An expansion joint of at least 5 mm must be created between the edge frame profile and face edges of the **terraza** profiles.

**Alternatively** to this, edge caps can be created with typical angle profiles of stainless steel or aluminium that are screwed to the profiles with stainless steel flat head screws 3.0 x 20 mm. Approx. 10 – 15 mm of air space must be left between the profile end and the vertical leg of the angle profile.

☛ *See Figure 18*

### Edge covering for round bends

The colour-matching end strips 6 x 40 mm can be used for covering the profile cut edges of round bends. The round bend can be created as an inner or outer bend, whereby the radius may not be less than 0.5 m.

☛ *See Figure 19*

### A Fastening holes

The fastening hole in the **terraza** profile must be predrilled roughly perpendicularly to the existing angle/rounding in the area of the screw channel of the profile tongue with  $\varnothing$  4 mm. The through-hole in the end strip must be drilled 2 mm larger than the screw diameter.

☛ *See Figure 20*

For stability reasons, the fastening of the end strip must take place on max. every second profile and the screw spacing must be max. 30 cm. The strips must always be screwed at the end.

Longitudinal joints of the end strips must be created with at least 5 mm expansion joint.

### B Screwing

The end strip is fastened with universal screw H 6 x 45 mm. A spacer sleeve K7 must be placed between the end strip and profile cut edge. Colour-matching end caps can be snapped onto the screw heads, if necessary.

- ① End cap
- ② Universal screw H 6 x 45
- ③ End strip 6 x 40
- ④ Spacer sleeve K7

Figure 17

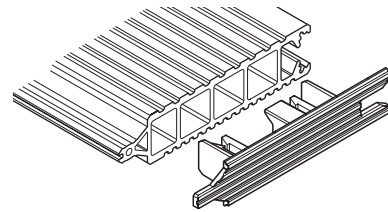

Figure 18

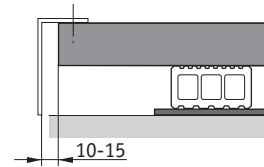

Figure 19

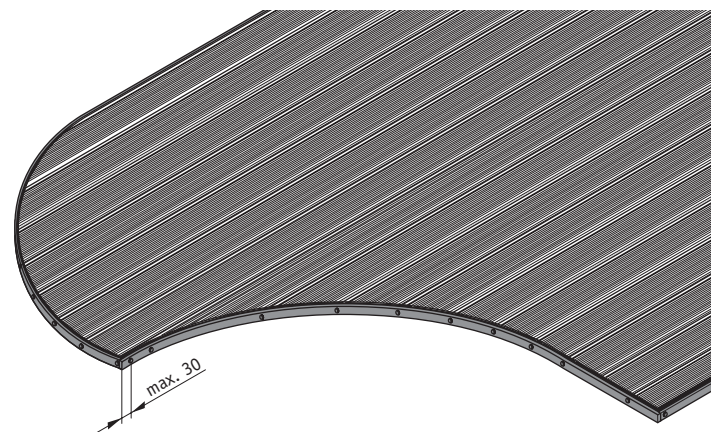

Figure 20

